

SIZE (MM)	"A"	"T"	"E"	"D"	"N"	TILT	TPI
28	1.130 ±.010	1.085 ±.010	0.978 ±.010	0.515 ±.015	1.060 MAX	2.22°	8
33	1.300 ±.010	1.255 ±.010	1.148 ±.010	0.515 ±.015	1.230 MAX	1.88°	8
38	1.515 ±.010	1.460 ±.010	1.363 ±.010	0.515 ±.015	1.440 MAX	1.60°	8
48	1.915 ±.010	1.860 ±.010	1.763 ±.010	0.515 ±.015	1.805 MAX	1.25°	8

Ⓑ

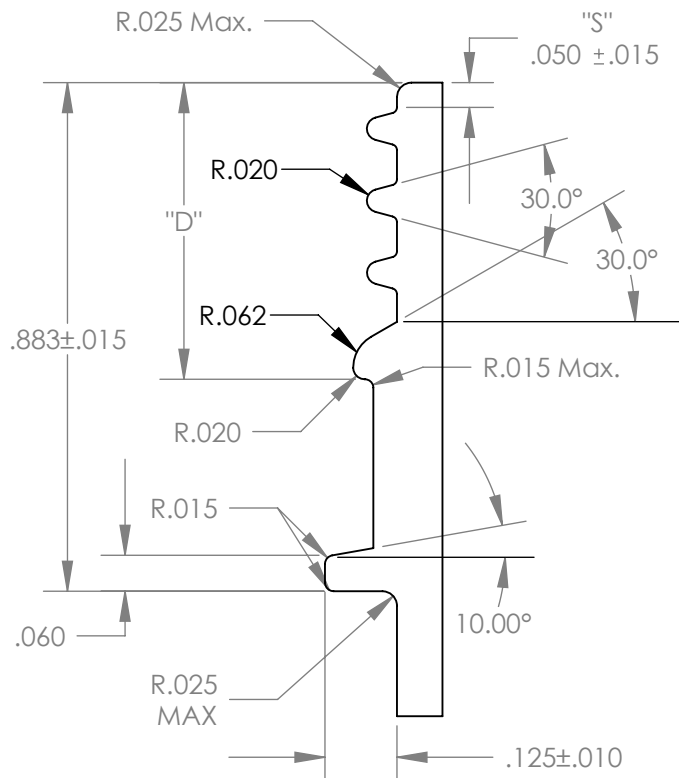
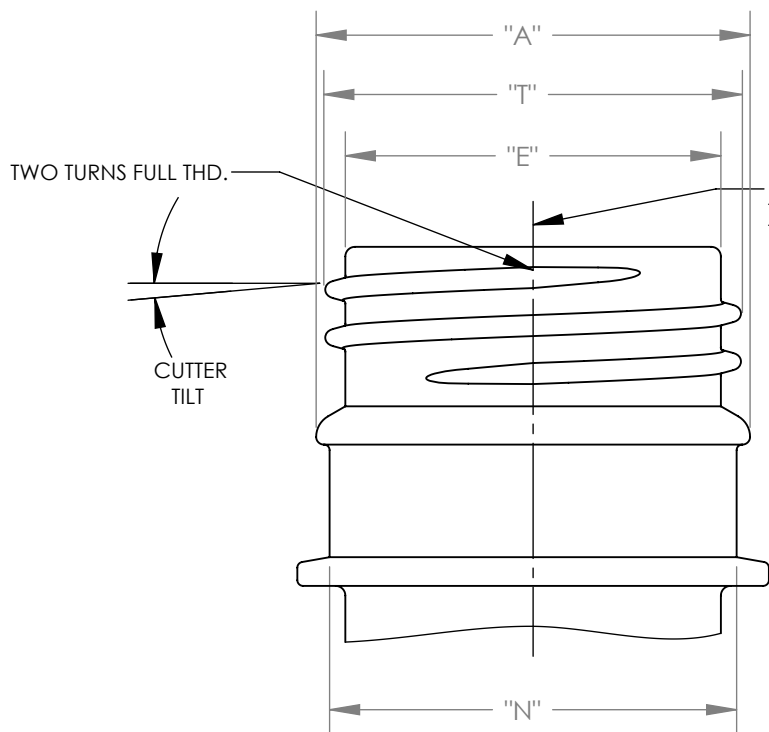

REVISIONS				
ZONE	REV.	DESCRIPTION	DATE	APPROVED
	A	CHANGED NAME IN TITLE BLOCK FROM ALCOA TO HOFFER	9/6/98	SJL
	B	REMOVED 43MM	9/7/00	SJL
	B1	REDRAWN IN CAD	3/28/08	WEI

UNLESS OTHERWISE SPECIFIED:

DIMENSIONS ARE IN INCHES
 TOLERANCES:
 FRACTIONAL ±
 ANGULAR: ± 1°
 TWO PLACE DECIMAL ± .010
 THREE PLACE DECIMAL ± .005

INTERPRET GEOMETRIC TOLERANCING PER:

MATERIAL

FINISH

DO NOT SCALE DRAWING

	NAME	DATE
DRAWN	WEI	3/28/08
DESIGN APPROVED		

COMMENTS:

THREAD CUTTER SIZE - .750 DIA
 FILLETS NOT GIVEN - MAX. .020 R
 NECK I.D. AND O.D. IS OPTIONAL

Hoffer Plastics Corp.
 500 N. Collins St.
 So. Elgin, Il. 60177



TITLE:

DROP-LOK® FINISH FOR PET

SIZE	DWG. NO.	REV
A	1763	B1

SCALE: 1:1 Shrink: SHEET 1 OF 1

PROPRIETARY AND CONFIDENTIAL
 THE INFORMATION CONTAINED IN THIS DRAWING IS THE SOLE PROPERTY OF HOFFER PLASTICS CORP. ANY REPRODUCTION IN PART OR AS A WHOLE WITHOUT THE WRITTEN PERMISSION OF HOFFER PLASTICS CORP. IS PROHIBITED.